

Five-pin soil transmitter (Type 485)

PR-3001-TR-ECTHPH-N01

Ver 2.0



Chapter 1 Product Introduction

1.1 Product overview

The transmitter has stable performance, high sensitivity, fast response, stable output, and is suitable for various soil qualities. It is an important tool for observing and studying the occurrence, evolution, improvement and water and salt dynamics of saline soil. By measuring the dielectric constant of the soil, it can directly and stably reflect the true moisture content of various soils. It can measure the volume percentage of soil moisture, which is a soil moisture measurement method that meets the current international standards. Can be buried in the soil for a long time, resistant to long-term electrolysis, corrosion resistance, vacuum potting, and completely waterproof.

The transmitter is suitable for soil moisture monitoring, scientific experiments, water-saving irrigation, greenhouses, flowers and vegetables, grassland pastures, soil rapid testing, plant cultivation, sewage treatment, precision agriculture and other occasions for temperature and humidity, electrical conductivity, PH value testing .

1.2 Features

- The seven items of soil moisture content, electrical conductivity, temperature, nitrogen, phosphorus, potassium and PH value are combined in one.
- Low threshold, few steps, fast measurement, no reagents, unlimited detection times.
- The electrode is made of specially treated alloy material, which can withstand strong external impact and is not easy to damage.
- Completely sealed, resistant to acid and alkali corrosion, can be buried in the soil or directly into the water for long-term dynamic testing.
- High precision, fast response, good interchangeability, probe insertion design to ensure accurate measurement and reliable performance.
- It can also be used for the conductivity of water and fertilizer integrated solutions, as well as other nutrient solutions and substrates.
- High pH measurement accuracy, up to ± 0.3 PH accuracy, fast response speed and good interchangeability.

1.3 Main parameters

DC power supply (default)	DC 4.5-30V
Maximum power	0.5W (24V DC Power supply)

consumption		
Working temperature	-20°C~+60°C	
Core chip temperature resistance	85°C	
Conductivity parameter	Range	0-20000us/cm
	Resolution	1us/cm
	Precision	±3%FS in the range of 0-10000us/cm; ±5%FS in the range of 10000-20000us/cm
Soil moisture parameters	Range	0-100%
	Resolution	0.1%
	Precision	0-50% ±2%, 50-100% ±3% (Brown soil, 60%,25°C)
Soil temperature parameter	Range	-40~80°C
	Resolution	Resolution : 0.1°C
	Precision	±0.5°C (25°C)
Soil PH parameter	Range	3~9PH
	Resolution	0.1
	Precision	±0.3PH
NPK parameters	Range	1-1999 mg/kg(mg/L)
	Resolution	1 mg/kg(mg/L)
	Precision	±2%FS
Conductivity temperature compensation	Built-in temperature compensation sensor, compensation range 0-50°C	
Protection level	IP68	
Probe material	Anti-corrosion special electrode	
Sealing material	Black flame-retardant epoxy resin	
Default cable length	2M	
Dimensions	45*15*123mm	

Output signal	RS485(Modbus protocol)
---------------	------------------------

Shell size

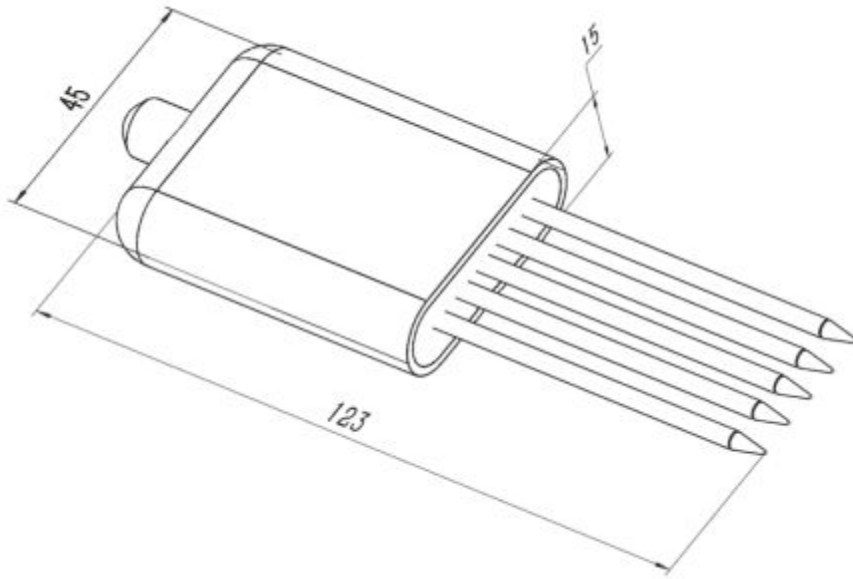

Equipment size drawing (unit: mm)

1.4 System frame diagram

单接

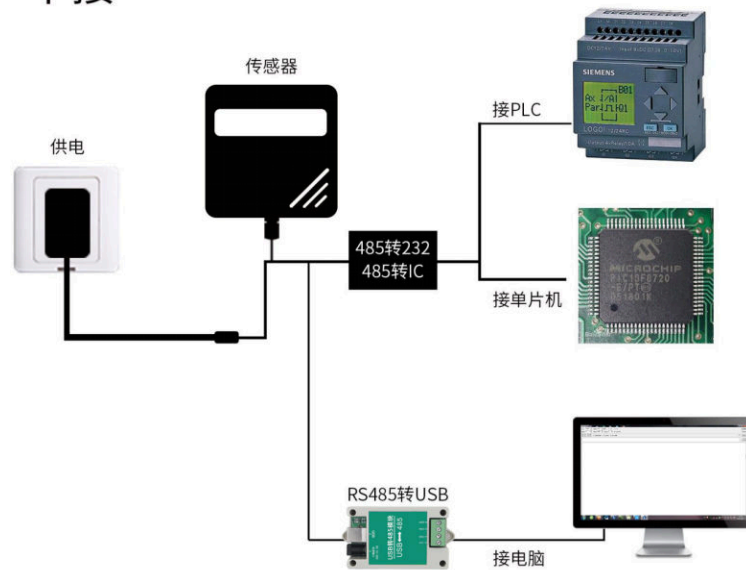

This product can also be combined with multiple sensors on a 485 bus. In theory, one bus can be used for 254 485 sensors, and the other end is connected to a PLC with a 485 interface, and a single-chip microcomputer is connected through a 485 interface chip, or USB to 485 can be used. Computer connection, use the sensor configuration tool provided by our company to configure and test (only one device can be connected when using the configuration software)。

多接

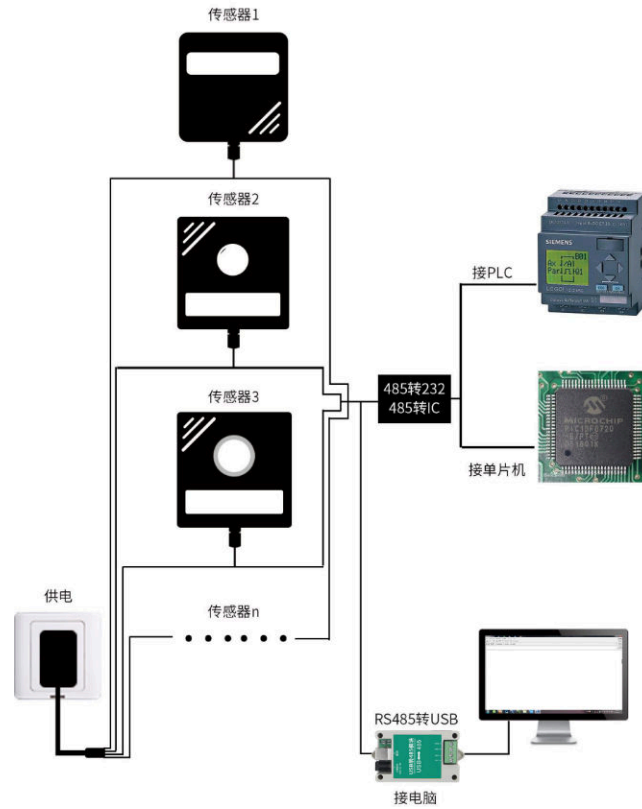

Chapter 2 Hardware Connections

2.2 Interface description

Wide-voltage power supply input can be 4.5~30V. When wiring the 485 signal line, pay attention to the two lines A/B not to be reversed, and the addresses of multiple devices on the bus must not conflict.

2.2.1 Sensor wiring



Thread color	Description	Remark
Brown	Power positive	4.5~30V DC
Black	Power ground	GND
yellow	485-A	485-A
Blue	485-B	485-B

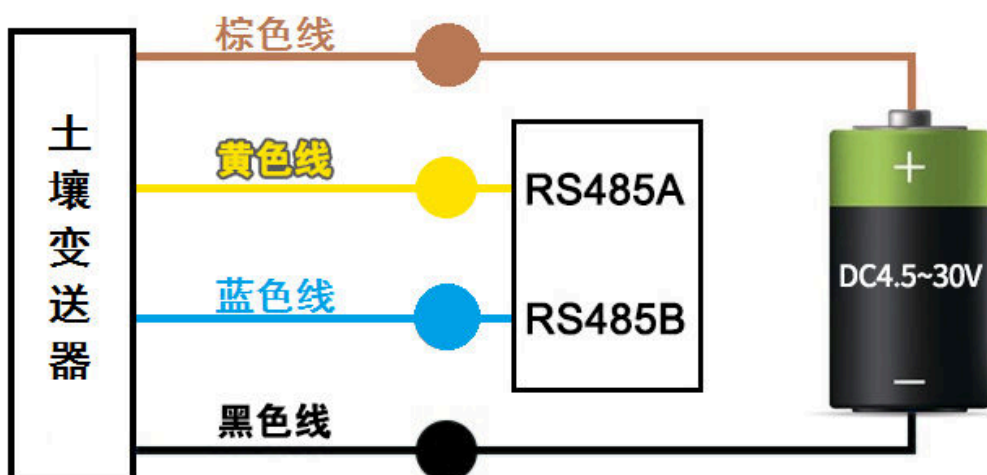

Chapter 3 How to Use

Since the electrode directly measures the conductivity of the soluble salt ions in the soil, the soil volumetric water content must be higher than about 20%

when the soluble ions in the soil can accurately reflect the conductivity of the soil. In the long-term observation, the measured value after irrigation or rainfall is closer to the true level. If you are performing a quick test, you can water the soil to be tested first, and perform the measurement after the water is fully penetrated.

If you are measuring on a hard surface, you should drill holes first (the hole diameter should be smaller than the probe diameter), then insert the soil and compact the soil before measuring; the transmitter should be protected from violent vibration and impact, let alone knocked with hard objects Hit. Because the transmitter is a black package, the transmitter will heat up rapidly (up to 50°C) under strong sunlight. In order to prevent excessive temperature from affecting the temperature measurement of the transmitter, please place it in the field or in the field. Pay attention to shading and protection when using.

3.1 Quick test method

Select a suitable measurement location, avoid rocks, ensure that the steel needle does not touch hard objects, throw away the surface soil according to the required measurement depth, maintain the original tightness of the soil below, hold the sensor vertically and insert it into the soil. Do not shake left and right. It is recommended to measure multiple times to find the average value within a small range of a measuring point.



3.2 Buried measurement method

Dig a pit with a diameter of >20cm vertically, insert the transmitter steel needle horizontally into the pit wall at a predetermined depth, and fill the pit tightly. After a period of stability, measurement and measurement can be

carried out continuously for several days, months or even longer. Record.

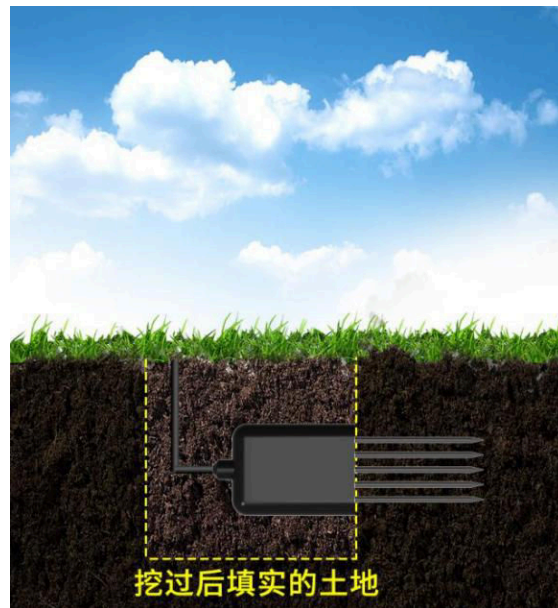

3.3 Matters needing attention

1. All steel needles must be inserted into the soil during measurement.
2. Avoid strong sunlight directly shining on the transmitter and cause the temperature to be too high. Pay attention to lightning protection when using in the field.
3. Do not bend the steel needle violently, pull the lead wire of the transmitter forcefully, and do not hit or hit the transmitter violently.
4. The transmitter's protection level is IP68, and the transmitter can be completely immersed in water.
5. Due to the presence of radio frequency electromagnetic radiation in the air, it is not suitable to stay in the air for a long time with electricity.

Chapter 4 Configuration Software Installation and Use

Our company provides the supporting "485 parameter configuration software", which can conveniently use the computer to read the parameters of the sensor, and at the same time flexibly modify the device ID and address of the sensor.

Note that you need to ensure that there is only one sensor on the 485 bus when using the software to obtain it automatically.

4.1 Connect the sensor to the computer

After connecting the sensor to the computer through USB to 485 and supplying power, you can see the correct COM port in the computer (check the COM port in "My Computer—Properties—Device Manager—Port").

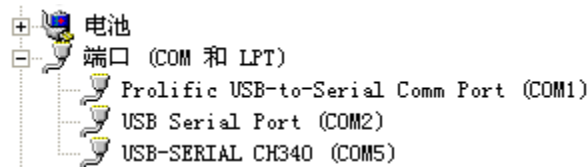

Open the data package, select "Debug software" --- "485 parameter

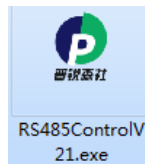

configuration software", find and open.

If the COM port is not found in the device manager, it means that you have not installed the USB to 485 driver (included in the data package) or the driver has not been installed correctly, please contact a technician for help.

4.2 Use of sensor monitoring software

①. The configuration interface is shown in the figure. First, obtain the serial port number according to the method in chapter 3.1 and select the correct serial port.

②. Click the test baud rate of the software, the software will test the baud rate and address of the current device, the default baud rate is 4800bit/s, and the default address is 0x01.

③. Modify the address and baud rate according to the needs of use, and at the same time, you can query the current function status of the device.

④. If the test is unsuccessful, please recheck the equipment wiring and 485

driver installation.

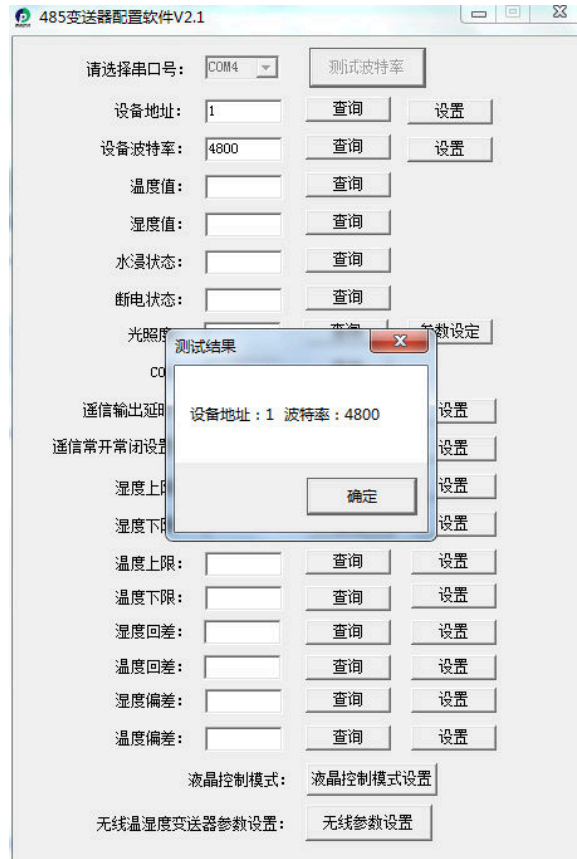

Chapter 5 Communication Protocol

5.1 Basic communication parameters

Code	8-bit binary
Data bit	8-bit
Parity bit	NO
Stop bit	1 bit
Error checking	CRC (Redundant Cyclic Code)
Baud rate	2400bit/s、4800bit/s、9600 bit/s Can be set, the factory default is 4800bit/s

5.2 Data frame format definition

Using Modbus-RTU communication protocol, the format is as follows:

Initial structure \geq 4 bytes of time

Address code = 1 byte

Function code = 1 byte

Data area = N bytes

Error check = 16-bit CRC code

Time to end structure \geq 4 bytes

Address code: the address of the transmitter, which is unique in the communication network (factory default 0x01).

Function code: The command function instruction issued by the host, this transmitter only uses function code 0x03 (read register data).

Data area: The data area is the specific communication data, pay attention to the high byte of the 16bits data first!

CRC code: two-byte check code.

Host query frame structure :

Address code	Function code	Register start address	Register length	Check code low	Check code high
1 byte	1 byte	2 byte	2 byte	1 byte	1 byte

Slave response frame structure :

Address code	Function code	Number of valid bytes	Data area	Second data area	Nth data area	Check code
1 byte	1 byte	1 byte	2 byte	2 byte	2 byte	2 byte

5.3 Register address

Register address	PLC or configuration address	Content	operate	Definition description
0000 H	40001 (Decimal)	Moisture content	Read only	Moisture content real-time value (expanded 10 times)
0001 H	40002 (Decimal)	Temperature value	Read only	Temperature real-time value (expanded 10 times)
0002 H	40003 (Decimal)	Conductivity	Read only	Real-time conductivity value
0003 H	40004 (Decimal)	PH value	Read only	PH real-time value (expanded ten times)

0004H	40005(Decimal)	Nitrogen content	Read only	Actual value of nitrogen content
0005H	40006(Decimal)	Phosphorus content	Read only	Actual value of phosphorus content
0006H	40007(Decimal)	Potassium content	Read only	Actual value of potassium content
0007 H	40008(Decimal)	salinity	Read only	Salinity real-time value
0008 H	40009 (Decimal)	Total dissolved solids TDS	Read only	TDS real-time value
0022 H	40035 (Decimal)	Conductivity temperature coefficient	Read and write	0-100 corresponds to 0.0%-10.0% Default 0.0%
0023 H	40036 (Decimal)	Salinity coefficient	Read and write	0-100 corresponds to 0.00-1.00 Default 55 (0.55)
0024 H	40037 (Decimal)	TDS coefficient	Read and write	0-100 corresponds to 0.00-1.00 Default 50 (0.5)
0050 H	40081 (Decimal)	Temperature calibration value	Read and write	Integer (expanded by 10 times)
0051 H	40082 (Decimal)	Water content calibration value	Read and write	Integer (expanded by 10 times)
0052 H	40083 (Decimal)	Conductivity calibration value	Read and write	Integer
0053 H	40083 (Decimal)	PH calibration value	Read and write	Integer
04E8 H	41001	Sixteen	Read	True value

	(Decimal)	higher nitrogen content coefficient	and write	(IEEE754 standard floating point type)
04E9 H	41002 (Decimal)	Sixteen lower nitrogen content coefficient	Read and write	
04EA H	41003 (Decimal)	Nitrogen content calibration value	Read and write	Integer
04F2 H	41011 (Decimal)	Sixteen higher phosphorus content coefficient	Read and write	True value (IEEE754 standard floating point type)
04F3 H	41012 (Decimal)	Sixteen lower phosphorus content coefficient	Read and write	
04F4 H	41013 (Decimal)	Phosphorus content calibration value	Read and write	Integer
04FC H	41021 (Decimal)	Sixteen higher potassium content coefficient	Read and write	True value (IEEE754 standard floating point type)
04FD H	41022 (Decimal)	Sixteen lower potassium content coefficient	Read and write	

04FE H	41023 (Decimal)	Potassium content calibration value	Read and write	Integer
07D0 H	42001 (Decimal)	Device address	Read and write	1~254 (出厂默认1)
07D1 H	42002 (Decimal)	Device baud rate	Read and write	0 for 2400 1 for 4800 2 for 9600

Note: The conductivity moisture equipment has no temperature value and its calibration value register

5.4 Communication protocol example and explanation

Example: Read the parameter value of the conductivity, temperature, moisture and PH four-in-one device (address 0x01)

Interrogation frame

Address code	Function code	Start address	Data length	Check code low byte	Check code high byte
0x01	0x03	0x00 0x00	0x00 0x04	0x44	0x09

Reply frame

Address code	Function code	Returns number of valid bytes	Moisture value	Temperature value	Conductivity value	PH value	Check code low byte	Check code high byte
0x01	0x03	0x08	0x02 0x92	0xFF 0x9B	0x03 0xE8	0x00 0x38	0x57	0xB6

Temperature calculation:

When the temperature is lower than 0 °C, the temperature data is uploaded in the form of complement code.

Temperature: FF9B H (hexadecimal) = -101 => temperature = -10.1°C

Moisture calculation:

Moisture: 292 H (hexadecimal) = 658 => Humidity = 65.8%, that is, the soil volumetric moisture content is 65.8%.

Conductivity calculation:

Conductivity: 3E8 H (hexadecimal) = 1000 Conductivity = 1000 us/cm

PH value calculation:

PH value: 38H (hexadecimal) = 56 => PH value = 5.6

Chapter 6 Common Problems and Solutions

No output or output error

Possible reasons:

- ① The computer has a COM port, and the selected port is incorrect.
- ② The baud rate is wrong.
- ③ The 485 bus is disconnected, or the A and B wires are connected reversely.
- ④ . Too much equipment or too long wiring, power supply nearby, add 485 booster, and add 120Ω terminal resistance at the same time.
- ⑤ The USB to 485 driver is not installed or damaged.
- ⑥ The equipment is damaged.