

- ① Hall Effect sensor ICs in SOT-23 packages, e.g. AH1751
- ② Implemented as 74LVC1G58 multi-function gate with pin 3 tied to pin 1
- ③ Implemented as 74LVC1G97 multi-function gate with pin 3 tied to GND
- ④ Implemented as 74LVC1G97 multi-function gate with pin 1 tied to GND

User interface

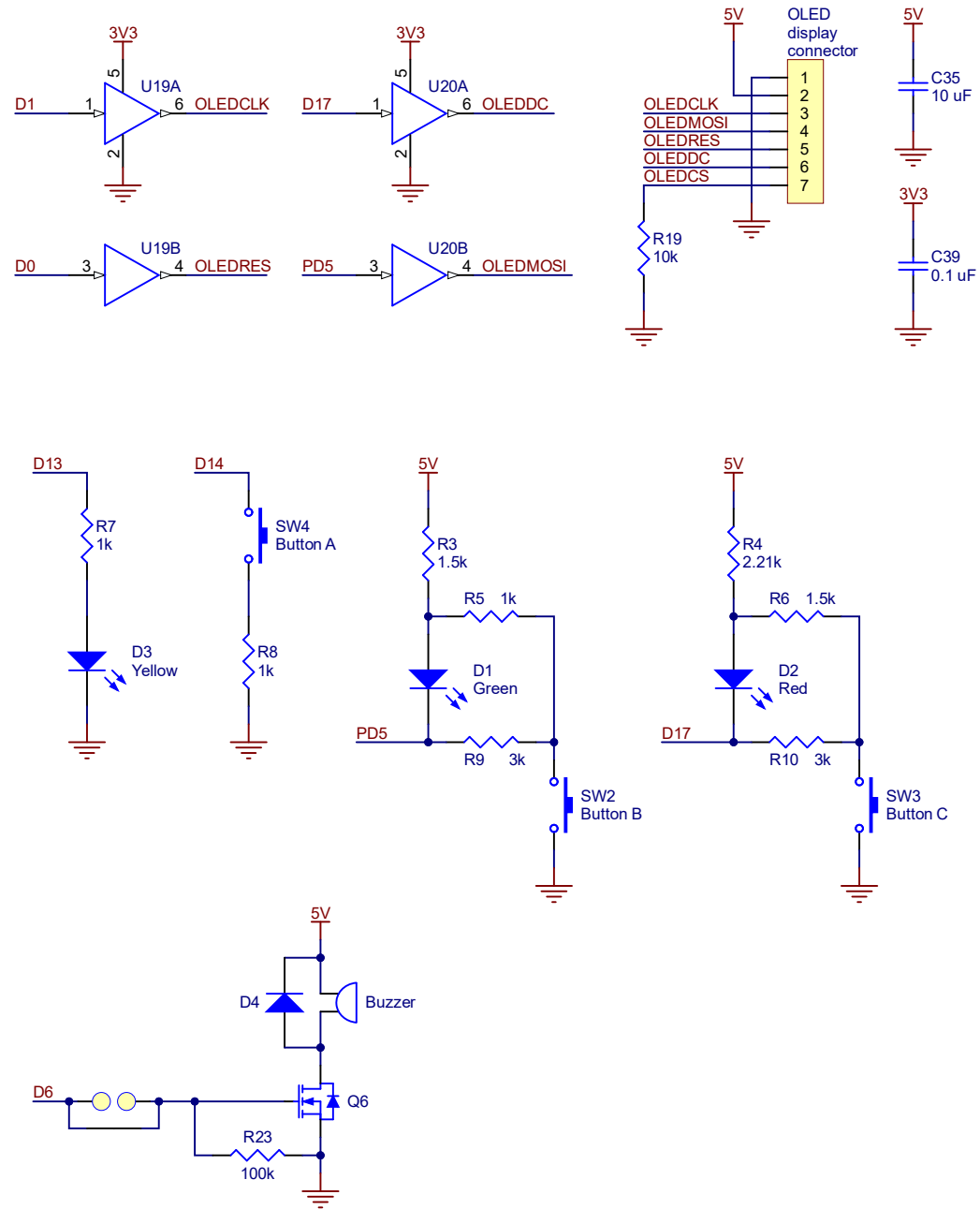

Inertial sensors

