



LD1117/A

LINEAR INTEGRATED CIRCUIT

LOW DROP FIXED AND ADJUSTABLE POSITIVE VOLTAGE REGULATORS

DESCRIPTION

The UTC **LD1117/A** is a low dropout, 3-terminal positive voltage regulator designed to provide output current up to 800mA/1A, There are adjustable version ($V_{REF}=1.25V$) and various fixed versions.

FEATURES

- * Low dropout voltage
- * Suitable for SCSI-2 active termination if V_{OUT} set to 2.85V
- * Output current up to 0.8A for 1117 and 1.0A for 1117A
- * Built-in current limit and over temperature protection
- * Low current consumption
- * Support MLCC

ORDERING INFORMATION

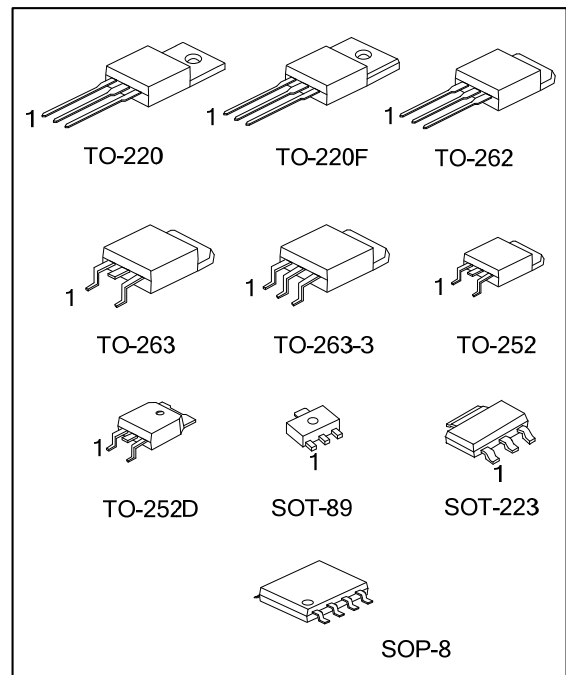

Ordering Number		Package	② Pin Assignment			③ Packing
Lead Free	Halogen Free		Pin Code	1	2	
LD1117①L-xx-AA3-②-③	LD1117①G-xx-AA3-②-③	SOT-223	A	G	O	R: Tape Reel T: Tube
LD1117①L-xx-AB3-②-③	LD1117①G-xx-AB3-②-③	SOT-89	B	O	G	
LD1117①L-xx-TA3-②-③	LD1117①G-xx-TA3-②-③	TO-220	C	G	I	
LD1117①L-xx-TF3-②-③	LD1117①G-xx-TF3-②-③	TO-220F	D	I	G	
LD1117①L-xx-TN3-②-③	LD1117①G-xx-TN3-②-③	TO-252	GOOlxOOx			
LD1117①L-xx-TND-②-③	LD1117①G-xx-TND-②-③	TO-252D				
LD1117①L-xx-T2Q-②-③	LD1117①G-xx-T2Q-②-③	TO-262				
LD1117①L-xx-TQ2-②-③	LD1117①G-xx-TQ2-②-③	TO-263				
LD1117①L-xx-TQ3-②-③	LD1117①G-xx-TQ3-②-③	TO-263-3				
LD1117①L-xx-S08-②-③	LD1117①G-xx-S08-②-③	SOP-8				

Notes: 1. ① : Current code: Blank: 800mA A: 1A
 2. Pin Assignment: I: V_{IN} O: V_{OUT} G: GND/ADJ
 3. xx: Output Voltage, Refer to Marking Information.

<p>LD1117①G-xx-AA3-②-③</p> <p>(1)Packing Type (2)Pin Assignment (3)Package Type (4)Output Voltage Code (5)Green Package (6)Current Code</p>	<p>(1) R: Tape Reel, T: Tube (2) refer to Pin Assignment (3) AA3: SOT-223, AB3: SOT-89, TA3:TO-220, TF3: TO-220F, TN3: TO-252, TND: TO-252D, T2Q: TO-262, TQ2: TO-263, TQ3: TO-263-3, S08: SOP-8 (4) xx: refer to Marking Information (5) G: Halogen Free and Lead Free, L: Lead Free (6) Blank: 800mA, A: 1A</p>
--	--

MARKING INFORMATION

PACKAGE	VOLTAGE CODE	MARKING
SOT-89		
SOT-223	12 : 1.2V 15 : 1.5V 18 : 1.8V 25 : 2.5V 2J : 2.85V	
TO-220 TO-220F TO-252 TO-252D TO-262 TO-263 TO-263-3	30 : 3.0V 33 : 3.3V 36 : 3.6V 50 : 5.0V AD : ADJ	
SOP-8		

Note: Current code: Blank: 0.8A A: 1A

PIN CONFIGURATION of SOP-8

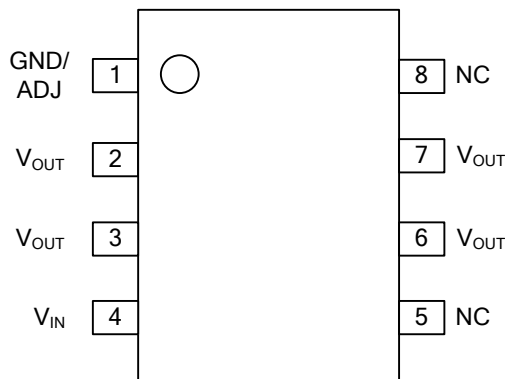

■ BLOCK DIAGRAM

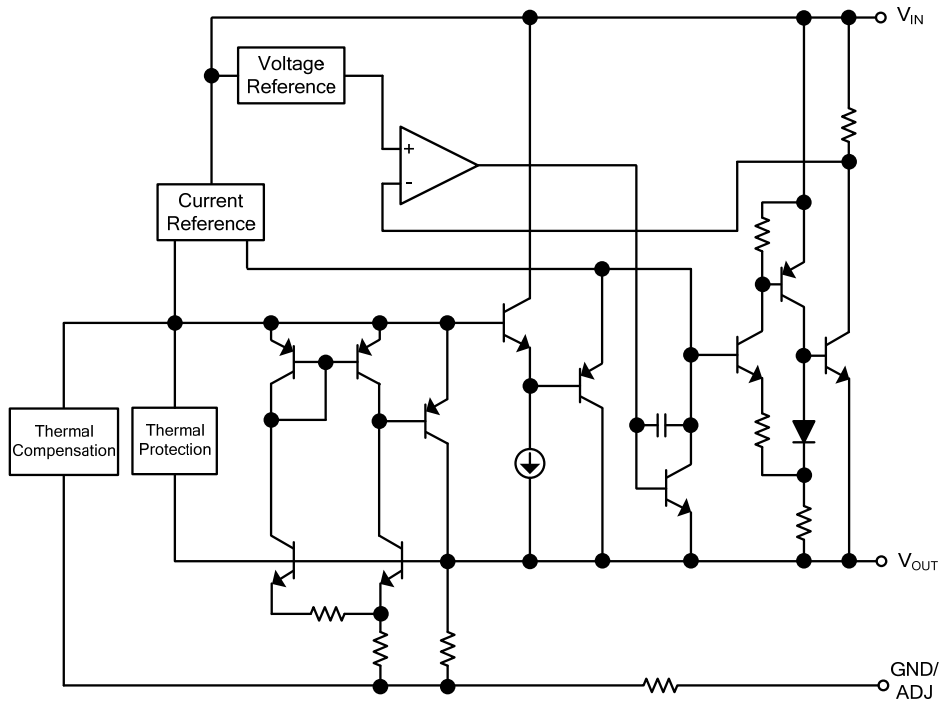

■ ABSOLUTE MAXIMUM RATINGS ($T_A=25^{\circ}\text{C}$)

PARAMETER	SYMBOL	RATINGS	UNIT
DC Input Voltage	V_{IN}	18	V
Power Dissipation	P_D	Internally limited	
Junction Temperature	T_J	+150	$^{\circ}\text{C}$
Operating Temperature (Note 2)	T_{OPR}	-20 ~ +125	$^{\circ}\text{C}$
Storage temperature	T_{STG}	-65 ~ +150	$^{\circ}\text{C}$

Notes: 1. Absolute maximum ratings are those values beyond which the device could be permanently damaged.

Absolute maximum ratings are stress ratings only and functional device operation is not implied.

2. This condition is only determined from design. It can't be 100% tested in mass production.

■ RECOMMENDED OPERATING RATINGS

PARAMETER	SYMBOL	RATINGS	UNIT
Input Voltage	V_{IN}	15	V
Operating Junction Temperature	T_J	-20 ~ +125	$^{\circ}\text{C}$

■ THERMAL DATA

PARAMETER		SYMBOL	RATINGS	UNIT
Junction to Ambient	SOT-223	θ_{JA}	165	$^{\circ}\text{C}/\text{W}$
	SOT-89		180	$^{\circ}\text{C}/\text{W}$
	SOP-8		150	$^{\circ}\text{C}/\text{W}$
	TO-252/TO-252D		112	$^{\circ}\text{C}/\text{W}$
	TO-220		54	$^{\circ}\text{C}/\text{W}$
	TO-262/TO-263		64	$^{\circ}\text{C}/\text{W}$
Junction to Case	SOT-223	θ_{JC}	15	$^{\circ}\text{C}/\text{W}$
	SOT-89		50	$^{\circ}\text{C}/\text{W}$
	SOP-8		20	$^{\circ}\text{C}/\text{W}$
	TO-252/TO-252D		12	$^{\circ}\text{C}/\text{W}$
	TO-220/TO-262		4	$^{\circ}\text{C}/\text{W}$
	TO-263			

■ ELECTRICAL CHARACTERISTICS

($T_A=25^\circ\text{C}$, refer to the test circuits, $T_J=0 \sim 125^\circ\text{C}$, $C_O=10\mu\text{F}$ unless otherwise specified)

For LD1117/A-1.2

PARAMETER	SYMBOL	TEST CONDITIONS	MIN.	TYP.	MAX.	UNIT
Output Voltage	V_{OUT}	$V_{IN}=3.2\text{V}$, $I_{OUT}=10\text{mA}$, $T_J=25^\circ\text{C}$	1.176	1.200	1.224	V
Output Voltage	V_{OUT}	$V_{IN}=2.7$ to 8V LD1117 : $I_{OUT}=10\sim 800\text{mA}$ LD1117A : $I_{OUT}=10\sim 1000\text{mA}$	1.176	1.200	1.224	V
Line Regulation	ΔV_{OUT}	$V_{IN}=2.7$ to 8V, $I_{OUT}=10\text{mA}$		1	6	mV
Load Regulation	ΔV_{OUT}	$V_{IN}=2.7\text{V}$ LD1117 : $I_{OUT}=10\sim 800\text{mA}$ LD1117A : $I_{OUT}=10\sim 1000\text{mA}$		1	10	mV
Temperature stability	ΔV_{OUT}			0.5		%
Long Term Stability	ΔV_{OUT}	1000 hrs, $T_J=125^\circ\text{C}$		0.3		%
Operating Input Voltage	V_{IN}	$I_{OUT}=100\text{mA}$			15	V
Quiescent Current	I_Q	$V_{IN}\leq 10\text{V}$		5	10	mA
Current Limit	I_{LIMIT}	$V_{IN}=6.2\text{V}$, $T_J=25^\circ\text{C}$	LD1117	800		mA
			LD1117A	1000		
Minimum Load Current	$I_{O(MIN)}$	$V_{IN}=15\text{V}$		2	5	mA
Output Noise Voltage	e_N	$B=10\text{Hz}$ to 10KHz, $T_J=25^\circ\text{C}$		100		μV
Supply Voltage Rejection	SVR	$I_{OUT}=40\text{mA}$, $f=120\text{Hz}$, $T_J=25^\circ\text{C}$, $V_{IN}=4.2\text{V}$, $V_{RIPPLE}=1V_{PP}$	60	75		dB
Dropout Voltage	V_D	$I_{OUT}=100\text{mA}$		1.00	1.10	V
		$I_{OUT}=500\text{mA}$		1.15	1.25	
		$I_{OUT}=800\text{mA}$		1.20	1.30	
		$I_{OUT}=1\text{A}$		1.20	1.30	
Thermal Regulation		$T_A=25^\circ\text{C}$, 30ms Pulse		0.01	0.10	%/W

For LD1117/A-1.5

PARAMETER	SYMBOL	TEST CONDITIONS	MIN.	TYP.	MAX.	UNIT
Output Voltage	V_{OUT}	$V_{IN}=3.5\text{V}$, $I_{OUT}=10\text{mA}$, $T_J=25^\circ\text{C}$	1.470	1.500	1.530	V
Output Voltage	V_{OUT}	$V_{IN}=3$ to 8V LD1117 : $I_{OUT}=0\sim 800\text{mA}$ LD1117A : $I_{OUT}=0\sim 1000\text{mA}$	1.470	1.500	1.530	V
Line Regulation	ΔV_{OUT}	$V_{IN}=3$ to 8V, $I_{OUT}=0\text{mA}$		1	6	mV
Load Regulation	ΔV_{OUT}	$V_{IN}=3\text{V}$ LD1117 : $I_{OUT}=0\sim 800\text{mA}$ LD1117A : $I_{OUT}=0\sim 1000\text{mA}$		1	10	mV
Temperature stability	ΔV_{OUT}			0.5		%
Long Term Stability	ΔV_{OUT}	1000 hrs, $T_J=125^\circ\text{C}$		0.3		%
Operating Input Voltage	V_{IN}	$I_{OUT}=100\text{mA}$			15	V
Quiescent Current	I_Q	$V_{IN}\leq 10\text{V}$		5	10	mA
Current Limit	I_{LIMIT}	$V_{IN}=6.5\text{V}$, $T_J=25^\circ\text{C}$	LD1117	800		mA
			LD1117A	1000		
Output Noise Voltage	e_N	$B=10\text{Hz}$ to 10KHz, $T_J=25^\circ\text{C}$		100		μV
Supply Voltage Rejection	SVR	$I_{OUT}=40\text{mA}$, $f=120\text{Hz}$, $T_J=25^\circ\text{C}$, $V_{IN}=4.5\text{V}$, $V_{RIPPLE}=1V_{PP}$	60	75		dB
Dropout Voltage	V_D	$I_{OUT}=100\text{mA}$		1.00	1.10	V
		$I_{OUT}=500\text{mA}$		1.15	1.25	
		$I_{OUT}=800\text{mA}$		1.20	1.30	
		$I_{OUT}=1\text{A}$		1.20	1.30	
Thermal Regulation		$T_A=25^\circ\text{C}$, 30ms Pulse		0.01	0.10	%/W

■ ELECTRICAL CHARACTERISTICS(Cont.)

For LD1117/A-1.8

PARAMETER	SYMBOL	TEST CONDITIONS	MIN.	TYP.	MAX.	UNIT
Output Voltage	V_{OUT}	$V_{IN}=3.8V, I_{OUT}=10mA, T_J=25^{\circ}C$	1.764	1.800	1.836	V
Output Voltage	V_{OUT}	$V_{IN}=3.3$ to 8V LD1117 : $I_{OUT}=0\sim 800mA$ LD1117A : $I_{OUT}=0\sim 1000mA$	1.764	1.800	1.836	V
Line Regulation	ΔV_{OUT}	$V_{IN}=3.3$ to 8V, $I_{OUT}=0mA$		1	6	mV
Load Regulation	ΔV_{OUT}	$V_{IN}=3.3V$ LD1117 : $I_{OUT}=0\sim 800mA$ LD1117A : $I_{OUT}=0\sim 1000mA$		1	10	mV
Temperature stability	ΔV_{OUT}			0.5		%
Long Term Stability	ΔV_{OUT}	1000 hrs, $T_J=125^{\circ}C$		0.3		%
Operating Input Voltage	V_{IN}	$I_{OUT}=100mA$			15	V
Quiescent Current	I_Q	$V_{IN}\leq 10V$		5	10	mA
Current Limit	I_{LIMIT}	$V_{IN}=6.8V, T_J=25^{\circ}C$	LD1117	800		mA
			LD1117A	1000		
Output Noise Voltage	e_N	$B=10Hz$ to 10KHz, $T_J=25^{\circ}C$		100		μV
Supply Voltage Rejection	SVR	$I_{OUT}=40mA, f=120Hz, T_J=25^{\circ}C,$ $V_{IN}=5.5V, V_{RIPPLE}=1V_{PP}$	60	75		dB
Dropout Voltage	V_D		$I_{OUT}=100mA$	1.00	1.10	V
			$I_{OUT}=500mA$	1.15	1.25	
			$I_{OUT}=800mA$	1.20	1.30	
			$I_{OUT}=1A$	1.20	1.30	
Thermal Regulation		$T_A=25^{\circ}C, 30ms$ Pulse		0.01	0.10	%/W

For LD1117/A-2.5

PARAMETER	SYMBOL	TEST CONDITIONS	MIN.	TYP.	MAX.	UNIT
Output Voltage	V_{OUT}	$V_{IN}=4.5V, I_{OUT}=10mA, T_J=25^{\circ}C$	2.450	2.500	2.550	V
Output Voltage	V_{OUT}	$V_{IN}=3.9$ to 10V LD1117 : $I_{OUT}=0\sim 800mA$ LD1117A : $I_{OUT}=0\sim 1000mA$	2.450	2.500	2.550	V
Line Regulation	ΔV_{OUT}	$V_{IN}=3.9$ to 10V, $I_{OUT}=0mA$		1	6	mV
Load Regulation	ΔV_{OUT}	$V_{IN}=3.9V$ LD1117 : $I_{OUT}=0\sim 800mA$ LD1117A : $I_{OUT}=0\sim 1000mA$		1	10	mV
Temperature stability	ΔV_{OUT}			0.5		%
Long Term Stability	ΔV_{OUT}	1000 hrs, $T_J=125^{\circ}C$		0.3		%
Operating Input Voltage	V_{IN}	$I_{OUT}=100mA$			15	V
Quiescent Current	I_Q	$V_{IN}\leq 10V$		5	10	mA
Current Limit	I_{LIMIT}	$V_{IN}=7.5V, T_J=25^{\circ}C$	LD1117	800		mA
			LD1117A	1000		
Output Noise Voltage	e_N	$B=10Hz$ to 10KHz, $T_J=25^{\circ}C$		100		μV
Supply Voltage Rejection	SVR	$I_{OUT}=40mA, f=120Hz, T_J=25^{\circ}C,$ $V_{IN}=5.5V, V_{RIPPLE}=1V_{PP}$	60	75		dB
Dropout Voltage	V_D		$I_{OUT}=100mA$	1.00	1.10	V
			$I_{OUT}=500mA$	1.15	1.25	
			$I_{OUT}=800mA$	1.20	1.30	
			$I_{OUT}=1A$	1.20	1.30	
Thermal Regulation		$T_A=25^{\circ}C, 30ms$ Pulse		0.01	0.10	%/W

■ ELECTRICAL CHARACTERISTICS(Cont.)

For LD1117/A-2.85

PARAMETER	SYMBOL	TEST CONDITIONS	MIN	TYP	MAX	UNIT
Output Voltage	V_{OUT}	$V_{IN}=4.85V, I_{OUT}=10mA, T_J=25^{\circ}C$	2.793	2.850	2.907	V
Output Voltage	V_{OUT}	$V_{IN}=4.25$ to $10V$ LD1117 : $I_{OUT}=0\sim 800mA$ LD1117A : $I_{OUT}=0\sim 1000mA$	2.793	2.850	2.907	V
Line Regulation	ΔV_{OUT}	$V_{IN}=4.25$ to $10V, I_{OUT}=0mA$		1	6	mV
Load Regulation	ΔV_{OUT}	$V_{IN}=4.25V$ LD1117 : $I_{OUT}=0\sim 800mA$ LD1117A : $I_{OUT}=0\sim 1000mA$		1	10	mV
Temperature stability	ΔV_{OUT}			0.5		%
Long Term Stability	ΔV_{OUT}	1000 hrs, $T_J=125^{\circ}C$		0.3		%
Operating Input Voltage	V_{IN}	$I_{OUT}=100mA$			15	V
Quiescent Current	I_Q	$V_{IN}\leq 10V$		5	10	mA
Current Limit	I_{LIMIT}	$V_{IN}=7.85V, T_J=25^{\circ}C$	LD1117	800		mA
			LD1117A	1000		
Output Noise Voltage	e_N	$B=10Hz$ to $10KHz, T_J=25^{\circ}C$		100		μV
Supply Voltage Rejection	SVR	$I_{OUT}=40mA, f=120Hz, T_J=25^{\circ}C,$ $V_{IN}=5.85V, V_{RIPPLE}=1V_{PP}$	60	75		dB
Dropout Voltage	V_D		$I_{OUT}=100mA$	1.00	1.10	V
			$I_{OUT}=500mA$	1.15	1.25	
			$I_{OUT}=800mA$	1.20	1.30	
			$I_{OUT}=1A$	1.20	1.30	
Thermal Regulation		$T_A=25^{\circ}C, 30ms$ Pulse		0.01	0.10	%/W

For LD1117/A-3.0

PARAMETER	SYMBOL	TEST CONDITIONS	MIN.	TYP.	MAX.	UNIT
Output Voltage	V_{OUT}	$V_{IN}=5V, I_{OUT}=10mA, T_J=25^{\circ}C$	2.940	3.000	3.060	V
Output Voltage	V_{OUT}	$V_{IN}=4.5$ to $10V$ LD1117 : $I_{OUT}=0\sim 800mA$ LD1117A : $I_{OUT}=0\sim 1000mA$	2.940	3.000	3.060	V
Line Regulation	ΔV_{OUT}	$V_{IN}=4.5$ to $12V, I_{OUT}=0mA$		1	6	mV
Load Regulation	ΔV_{OUT}	$V_{IN}=4.5V$ LD1117 : $I_{OUT}=0\sim 800mA$ LD1117A : $I_{OUT}=0\sim 1000mA$		1	10	mV
Temperature stability	ΔV_{OUT}			0.5		%
Long Term Stability	ΔV_{OUT}	1000 hrs, $T_J=125^{\circ}C$		0.3		%
Operating Input Voltage	V_{IN}	$I_{OUT}=100mA$			15	V
Quiescent Current	I_Q	$V_{IN}\leq 15V$		5	10	mA
Current Limit	I_{LIMIT}	$V_{IN}=8V, T_J=25^{\circ}C$	LD1117	800		mA
			LD1117A	1000		
Output Noise Voltage	e_N	$B=10Hz$ to $10KHz, T_J=25^{\circ}C$		100		μV
Supply Voltage Rejection	SVR	$I_{OUT}=40mA, f=120Hz, T_J=25^{\circ}C,$ $V_{IN}=6V, V_{RIPPLE}=1V_{PP}$	60	75		dB
Dropout Voltage	V_D		$I_{OUT}=100mA$	1.00	1.10	V
			$I_{OUT}=500mA$	1.15	1.25	
			$I_{OUT}=800mA$	1.20	1.30	
			$I_{OUT}=1A$	1.20	1.30	
Thermal Regulation		$T_A=25^{\circ}C, 30ms$ Pulse		0.01	0.10	%/W

■ ELECTRICAL CHARACTERISTICS(Cont.)

For LD1117/A-3.3

PARAMETER	SYMBOL	TEST CONDITIONS	MIN.	TYP.	MAX.	UNIT
Output Voltage	V_{OUT}	$V_{IN}=5.3V, I_{OUT}=10mA, T_J=25^{\circ}C$	3.234	3.300	3.366	V
Output Voltage	V_{OUT}	$V_{IN}=4.75$ to 10V LD1117 : $I_{OUT}=0\sim 800mA$ LD1117A : $I_{OUT}=0\sim 1000mA$	3.234	3.300	3.366	V
Line Regulation	ΔV_{OUT}	$V_{IN}=4.75$ to 15V, $I_{OUT}=0mA$		1	6	mV
Load Regulation	ΔV_{OUT}	$V_{IN}=4.75V$ LD1117 : $I_{OUT}=0\sim 800mA$ LD1117A : $I_{OUT}=0\sim 1000mA$		1	10	mV
Temperature stability	ΔV_{OUT}			0.5		%
Long Term Stability	ΔV_{OUT}	1000 hrs, $T_J=125^{\circ}C$		0.3		%
Operating Input Voltage	V_{IN}	$I_{OUT}=100mA$			15	V
Quiescent Current	I_Q	$V_{IN}\leq 15V$		5	10	mA
Current Limit	I_{LIMIT}	$V_{IN}=8.3V, T_J=25^{\circ}C$	LD1117	800		mA
			LD1117A	1000		
Output Noise Voltage	e_N	$B=10Hz$ to 10KHz, $T_J=25^{\circ}C$		100		μV
Supply Voltage Rejection	SVR	$I_{OUT}=40mA, f=120Hz, T_J=25^{\circ}C,$ $V_{IN}=6.3V, V_{RIPPLE}=1V_{PP}$	60	75		dB
Dropout Voltage	V_D		$I_{OUT}=100mA$	1.00	1.10	V
			$I_{OUT}=500mA$	1.15	1.25	
			$I_{OUT}=800mA$	1.20	1.30	
			$I_{OUT}=1A$	1.20	1.30	
Thermal Regulation		$T_A=25^{\circ}C, 30ms$ Pulse		0.01	0.10	%/W

For LD1117/A-3.6

PARAMETER	SYMBOL	TEST CONDITIONS	MIN.	TYP.	MAX.	UNIT
Output Voltage	V_{OUT}	$V_{IN}=5.6V, I_{OUT}=10mA, T_J=25^{\circ}C$	3.528	3.600	3.672	V
Output Voltage	V_{OUT}	$V_{IN}=5$ to 10V LD1117 : $I_{OUT}=0\sim 800mA$ LD1117A : $I_{OUT}=0\sim 1000mA$	3.528	3.600	3.672	V
Line Regulation	ΔV_{OUT}	$V_{IN}=5$ to 15V, $I_{OUT}=0mA$		1	6	mV
Load Regulation	ΔV_{OUT}	$V_{IN}=5V$ LD1117 : $I_{OUT}=0\sim 800mA$ LD1117A : $I_{OUT}=0\sim 1000mA$		1	10	mV
Temperature stability	ΔV_{OUT}			0.5		%
Long Term Stability	ΔV_{OUT}	1000 hrs, $T_J=125^{\circ}C$		0.3		%
Operating Input Voltage	V_{IN}	$I_{OUT}=100mA$			15	V
Quiescent Current	I_Q	$V_{IN}\leq 15V$		5	10	mA
Current Limit	I_{LIMIT}	$V_{IN}=8.6V, T_J=25^{\circ}C$	LD1117	800		mA
			LD1117A	1000		
Output Noise Voltage	e_N	$B=10Hz$ to 10KHz, $T_J=25^{\circ}C$		100		μV
Supply Voltage Rejection	SVR	$I_{OUT}=40mA, f=120Hz, T_J=25^{\circ}C,$ $V_{IN}=6.6V, V_{RIPPLE}=1V_{PP}$	60	75		dB
Dropout Voltage	V_D		$I_{OUT}=100mA$	1.00	1.10	V
			$I_{OUT}=500mA$	1.15	1.25	
			$I_{OUT}=800mA$	1.20	1.30	
			$I_{OUT}=1A$	1.20	1.30	
Thermal Regulation		$T_A=25^{\circ}C, 30ms$ Pulse		0.01	0.10	%/W

■ ELECTRICAL CHARACTERISTICS(Cont.)

For LD1117/A-5.0

PARAMETER	SYMBOL	TEST CONDITIONS	MIN.	TYP.	MAX.	UNIT
Output Voltage	V_{OUT}	$V_{IN}=7V, I_{OUT}=10mA, T_J=25^{\circ}C$	4.900	5.000	5.100	V
Output Voltage	V_{OUT}	$V_{IN}=6.5$ to 15V LD1117 : $I_{OUT}=0\sim 800mA$ LD1117A : $I_{OUT}=0\sim 1.0A$	4.900	5.000	5.100	V
Line Regulation	ΔV_{OUT}	$V_{IN}=6.5$ to 15V, $I_{OUT}=0mA$		1	10	mV
Load Regulation	ΔV_{OUT}	$V_{IN}=6.5V$ LD1117 : $I_{OUT}=0\sim 800mA$ LD1117A : $I_{OUT}=0\sim 1000mA$		1	15	mV
Temperature stability	ΔV_{OUT}			0.5		%
Long Term Stability	ΔV_{OUT}	1000 hrs, $T_J=125^{\circ}C$		0.3		%
Operating Input Voltage	V_{IN}	$I_{OUT}=100mA$			15	V
Quiescent Current	I_Q	$V_{IN}\leq 15V$		5	10	mA
Current Limit	I_{LIMIT}	$V_{IN}=10V, T_J=25^{\circ}C$				mA
			LD1117	800		
			LD1117A	1000		
Output Noise Voltage	e_N	$B=10Hz$ to 10KHz, $T_J=25^{\circ}C$		100		μV
Supply Voltage Rejection	SVR	$I_{OUT}=40mA, f=120Hz, T_J=25^{\circ}C,$ $V_{IN}=8V, V_{RIPPLE}=1V_{PP}$	60	75		dB
Dropout Voltage	V_D	$I_{OUT}=100mA$		1.00	1.10	V
		$I_{OUT}=500mA$		1.15	1.25	
		$I_{OUT}=800mA$		1.20	1.30	
		$I_{OUT}=1A$		1.20	1.30	
Thermal Regulation		$T_A=25^{\circ}C, 30ms$ Pulse		0.01	0.10	%/W

For LD1117/A-ADJ

PARAMETER	SYMBOL	TEST CONDITIONS	MIN.	TYP.	MAX.	UNIT
Reference Voltage	V_{REF}	$V_{IN}-V_{OUT}=2V, I_{OUT}=10mA, T_J=25^{\circ}C$	1.225	1.25	1.275	V
Reference Voltage	V_{REF}	$V_{IN}-V_{OUT}=1.4$ to 10V LD1117 : $I_{OUT}=10\sim 800mA$ LD1117A : $I_{OUT}=10\sim 1000mA$	1.225	1.25	1.275	V
Line Regulation	ΔV_{OUT}	$V_{IN}-V_{OUT}=1.5$ to 13.75V, $I_{OUT}=10mA$		0.035	0.2	%
Load Regulation	ΔV_{OUT}	$V_{IN}-V_{OUT}=3V$ LD1117 : $I_{OUT}=10\sim 800mA$ LD1117A : $I_{OUT}=10\sim 1000mA$		0.1	0.4	%
Temperature stability	ΔV_{OUT}			0.50		%
Long Term Stability	ΔV_{OUT}	1000 hrs, $T_J=125^{\circ}C$		0.3		%
Operating Input Voltage	V_{IN}				15	V
Adjustment Pin Current	I_{ADJ}	$V_{IN}\leq 15V$		60	120	μA
Adjustment Pin Current Change	ΔI_{ADJ}	$V_{IN}-V_{OUT}=1.4$ to 10V, LD1117 : $I_{OUT}=10\sim 800mA$ LD1117A : $I_{OUT}=10\sim 1000mA$		1	5	μA
Minimum Load Current	$I_{O(MIN)}$	$V_{IN}=15V$		2	5	mA
Current Limit	I_{LIMIT}	$V_{IN}-V_{OUT}=5V, T_J=25^{\circ}C$				mA
			LD1117	800		
			LD1117A	1000		
Output Noise (% V_O)	e_N	$B=10Hz$ to 10KHz, $T_J=25^{\circ}C$		0.003		%
Supply Voltage Rejection	SVR	$I_{OUT}=40mA, f=120Hz, T_J=25^{\circ}C,$ $V_{IN}-V_{OUT}=3V, V_{RIPPLE}=1V_{PP}$	60	75		dB
Dropout Voltage	V_D	$I_{OUT}=100mA$		1.00	1.10	V
		$I_{OUT}=500mA$		1.15	1.25	
		$I_{OUT}=800mA$		1.20	1.30	
		$I_{OUT}=1A$		1.20	1.30	
Thermal Regulation		$T_A=25^{\circ}C, 30ms$ Pulse		0.01	0.10	%/W

■ TYPICAL APPLICATIONS

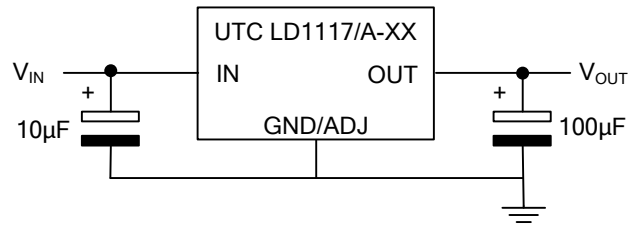

Fig.1 Tynca Application Circuit

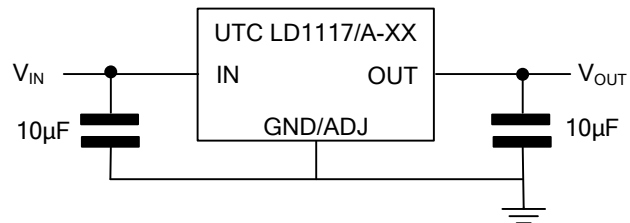

Fig.2 Tynca Application Circuit (FOR MLCC)

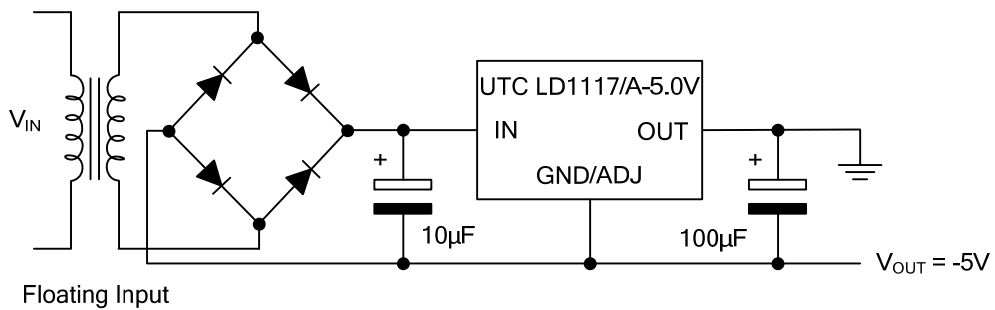

Fig.3 Negative Supply

■ TYPICAL APPLICATIONS(Cont.)

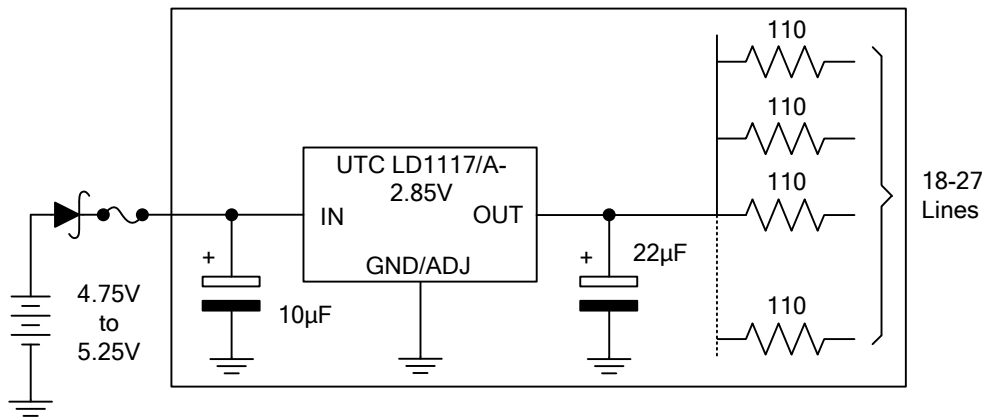

Fig.4 Active Terminator for SCSI-2 BUS

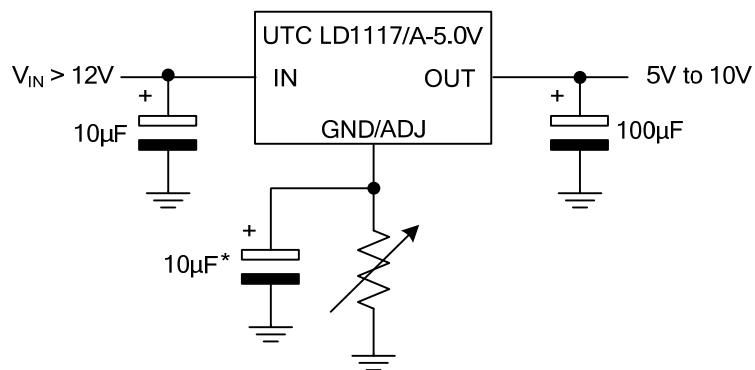

Fig.5 Circuit for Increasing Output Voltage

■ APPLICATION NOTE of LD1117/A ADJUSTABLE

The LD1117/A adjustable has a reference voltage of between the OUT and ADJ/GND pins. I_{ADJ} is 60µA typ. (120µA max.) and ΔI_{ADJ} is 1µA typ. (5µA max.).

R_1 is normally fixed to 120Ω.

From figure 6 we obtain:

$$V_{OUT} = V_{REF} + R_2(I_{ADJ} + I_{R1}) = V_{REF} + R_2(I_{ADJ} + V_{REF}/R_1) = V_{REF}(1 + R_2/R_1) + R_2 \times I_{ADJ}$$

Usually R_2 value is in the range of few KΩ, so the $R_2 \times I_{ADJ}$ product could be neglected; then the above expression becomes: $V_{OUT} = V_{REF}(1 + R_2/R_1)$

For better load regulation, realize a good Kelvin connection of R_1 and R_2 is important. Particularly R_1 connection must be realized very close to OUT and ADJ/GND pin, while R_2 ground connection must be placed as near as possible to the negative Load pin. Ripple rejection can be improved by introducing a 10µF electrolytic capacitor placed in parallel to the R_2 resistor (See Fig. 8)

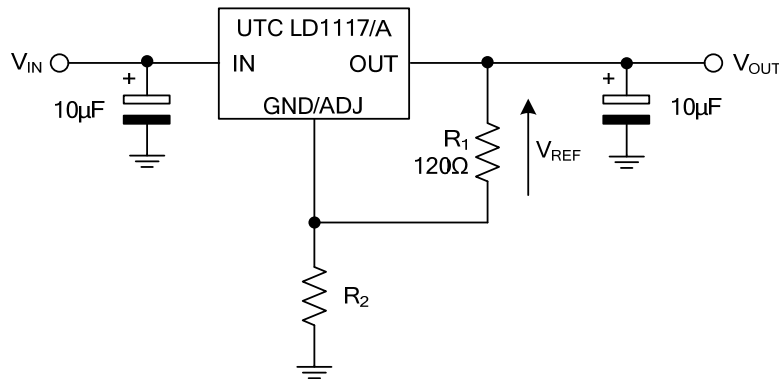

Fig.6 Adjustable Output Voltage Application Circuit

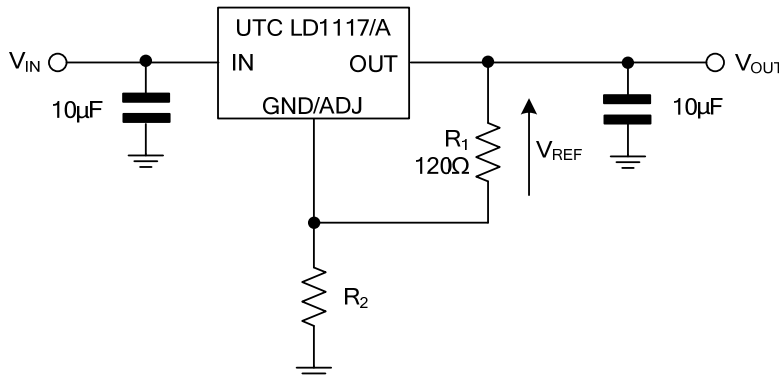

Fig.7 Adjustable Output Voltage Application Circuit (FOR MLCC)

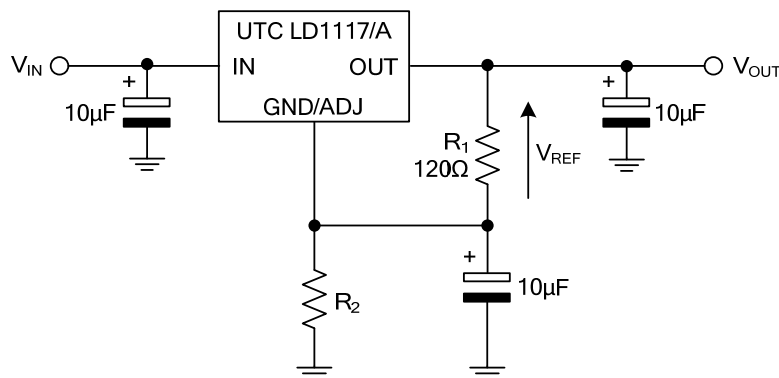
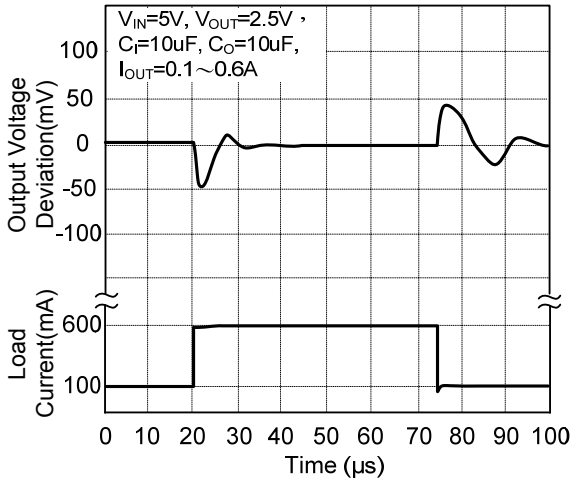

Fig.8 Adjustable Output Voltage Application with improved Ripple Rejection.

■ TYPICAL CHARACTERISTICS

Load Transient Response



Line Transient Response

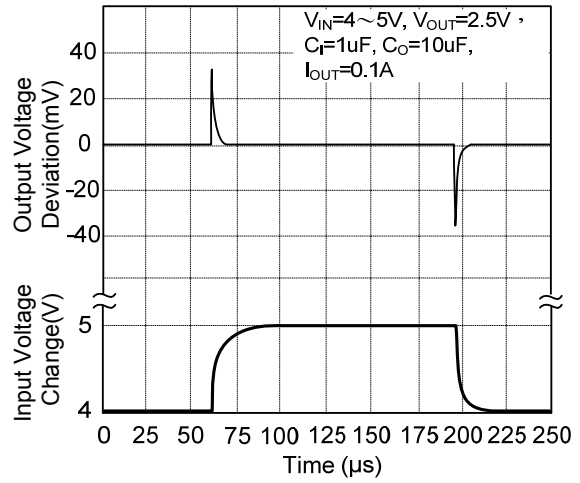

Dropout Voltage ($V_{IN}-V_{OUT}$)

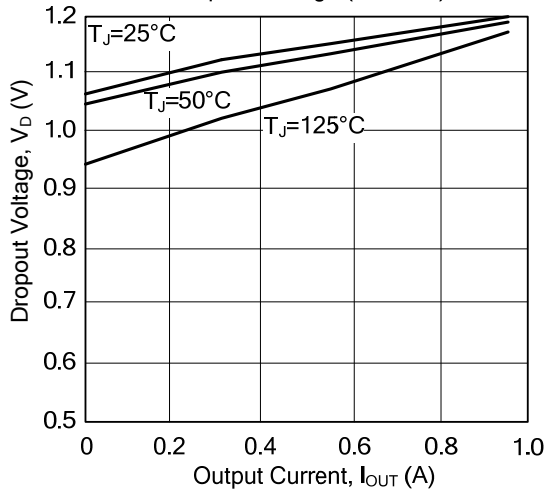

Ripple Rejection

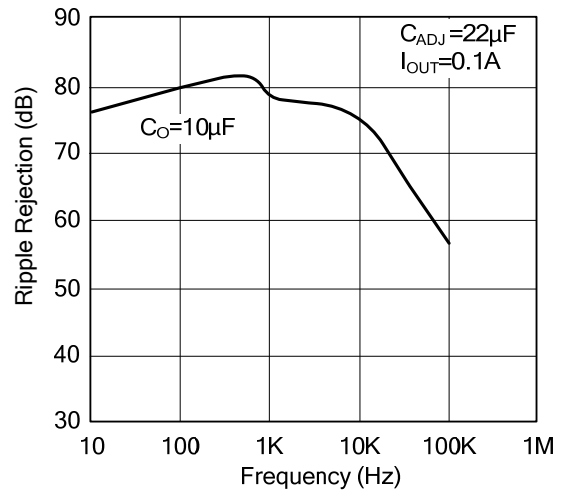

Adjust Pin Current

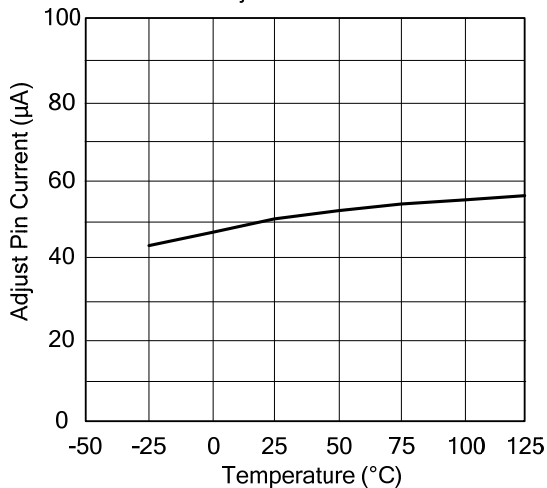

Temperature Stability

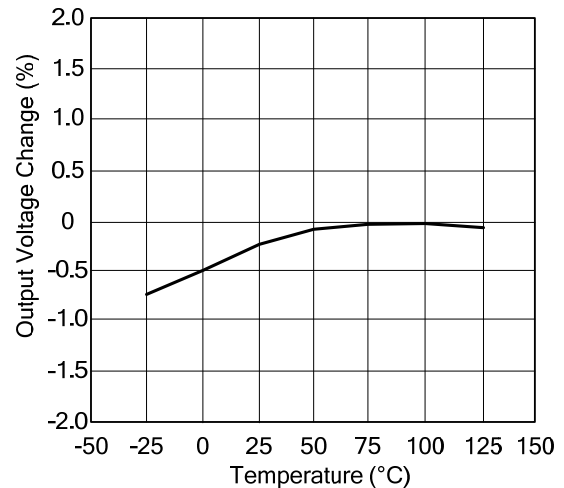

■ TYPICAL CHARACTERISTICS(Cont.)

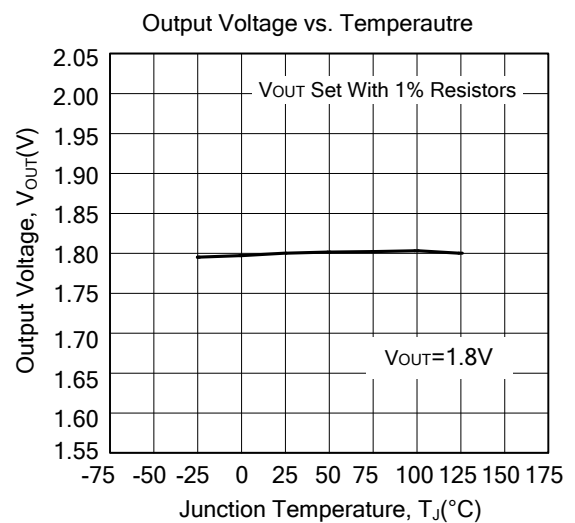
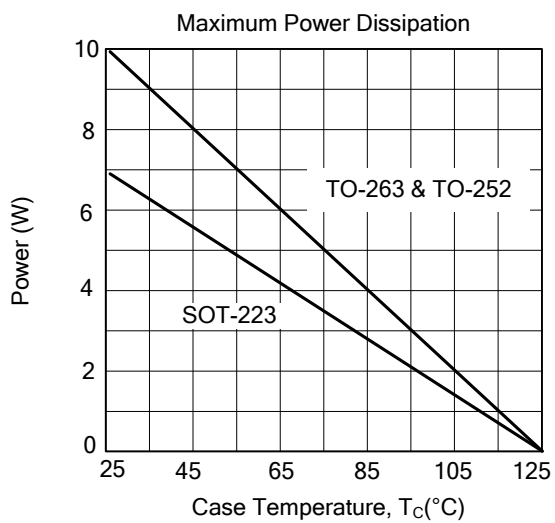
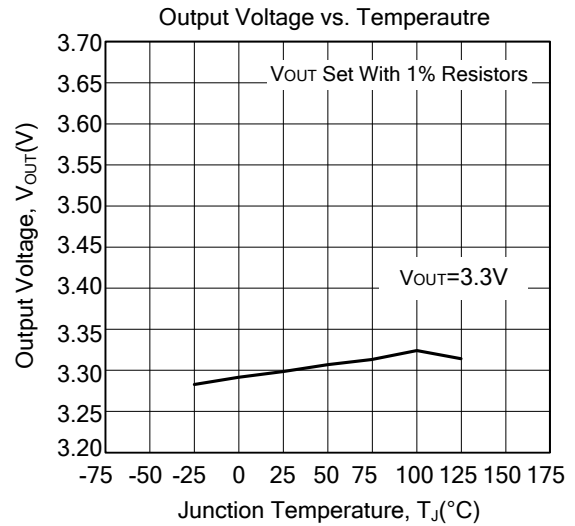
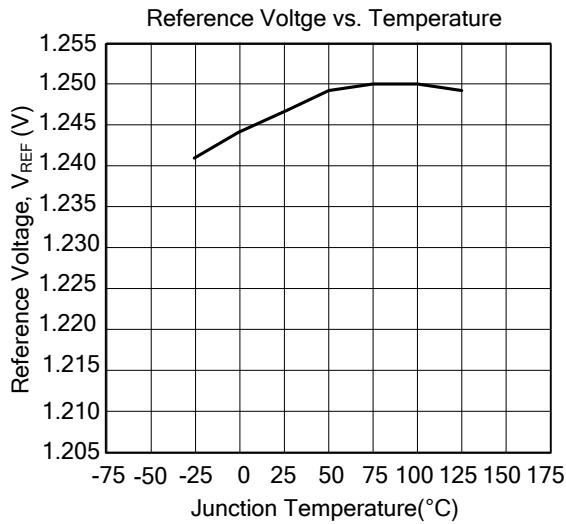
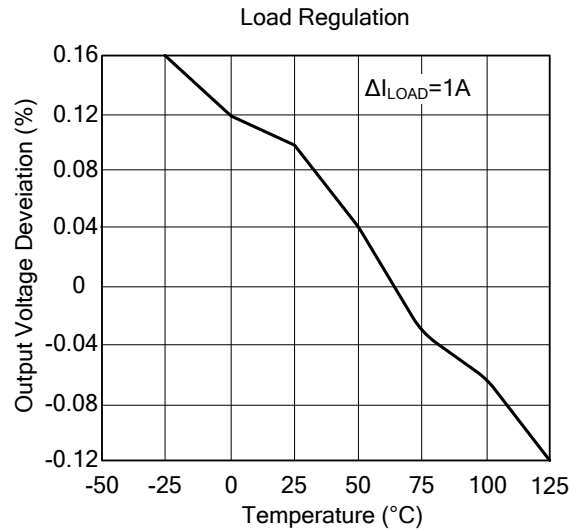
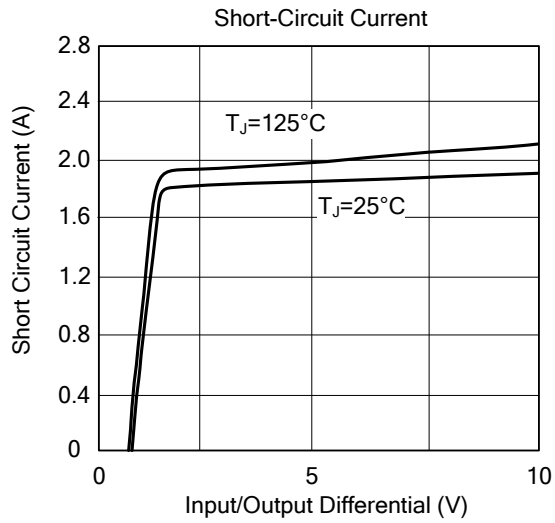

■ TYPICAL CHARACTERISTICS(Cont.)

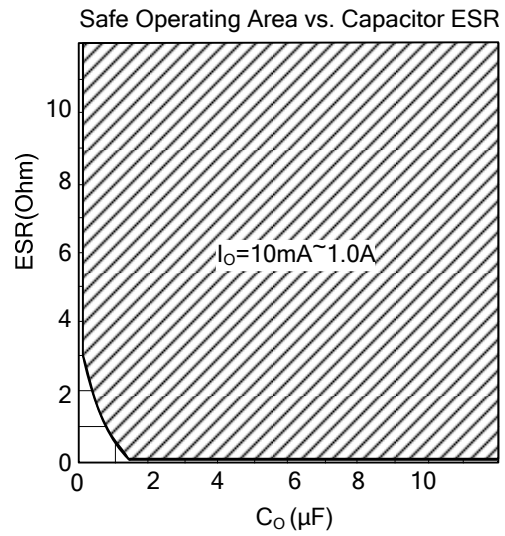
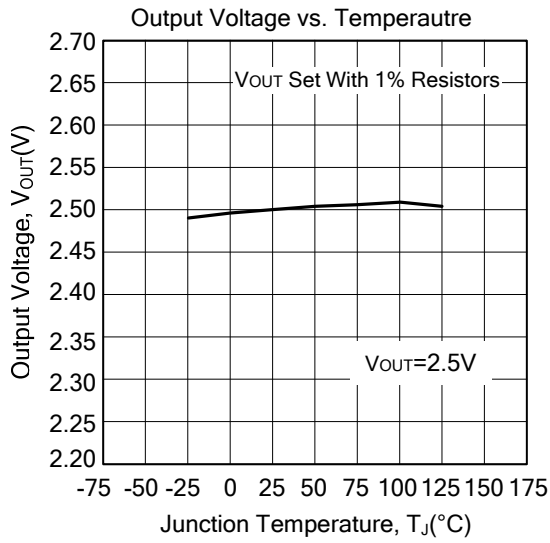

UTC assumes no responsibility for equipment failures that result from using products at values that exceed, even momentarily, rated values (such as maximum ratings, operating condition ranges, or other parameters) listed in products specifications of any and all UTC products described or contained herein. UTC products are not designed for use in life support appliances, devices or systems where malfunction of these products can be reasonably expected to result in personal injury. Reproduction in whole or in part is prohibited without the prior written consent of the copyright owner. The information presented in this document does not form part of any quotation or contract, is believed to be accurate and reliable and may be changed without notice.