

ISD1820 Voice Recorder Module User Guide

Rev 1.0, Oct 2012

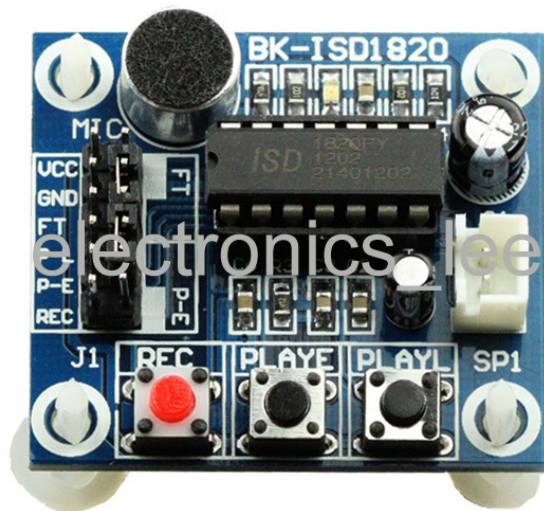

Table of Contents

1	Introduction	3
2	Feature	3
3	Application	3
4	Power Amplifier Circuit	5

1 Introduction

Voice Record Module is base on ISD1820, which a multiple-message record/playback device. It can offers true single-chip voice recording, no-volatile storage, and playback capability for 8 to 20 seconds. The sample is 3.2k and the total 20s for the Recorder.

This module use is very easy which you could direct control by push button on board or by Microcontroller such as Arduino, STM32, ChipKit etc. Frome these, you can easy control record , playback and repeat and so on.

2 Feature

- Push-button interface, playback can be edge or level activated
- Automatic power-dwon mode
- On-chip 8Ω speaker driver
- Signal 3V Power Supply
- Can be controlled both manually or by MCU
- Sample rate and duration changable by replacing a single resistor
- Record up to 20 seconds of audio
- Dimensions: 37 x 54 mm

3 Application

Typical schematic list as follows.

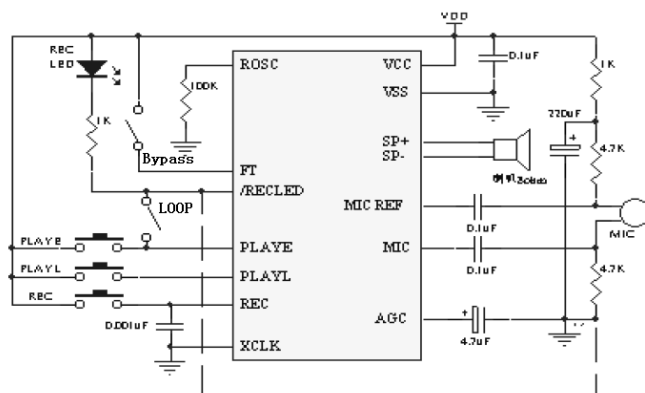

If you want change record duration, an external resistor is necessary to select the record duration and sampling frequency, which can range from 8 – 20 seconds (4-12kHz sampling frequency). The Voice Record Module of our provide default connect 100k resistor by short cap. So the default record duration is 10s.

ROSC	Duration	Sample Rate	Bandwidth
80K Ω	8 secs	8. 0KHz	3. 4KHz
100K Ω	10 secs	6. 4KHz	2. 6KHz
120K Ω	12 secs	5. 3KHz	2. 3KHz
160K Ω	16 secs	4. 0KHz	1. 7KHz
200K Ω	20 secs	3. 2KHz	1. 3KHz

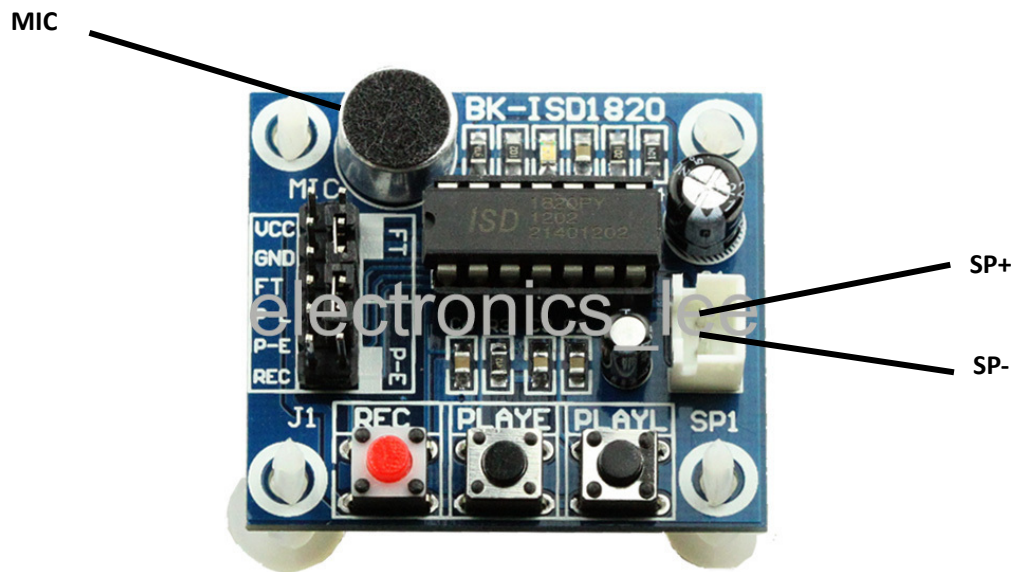

1. **VCC**– 3.3V power supply
2. **GND**– Power ground
3. **REC** – The REC input is an active-HIGH record signal. The module starts recording whenever REC is HIGH. This pin must remain HIGH for the duration of the recording. REC takes precedence over either playback(PLAYL or PLAYE) signal.
4. **PLAYE** – Playback, Edge-activated: When a HIGH-going transition is detected on continues until an End-of-Message (EOM) marker is encountered or the end of the memory space is reached.
5. **PLAYL** – Playback, Level-activated, when this input pin level transits for LOW to HIGH, a playback cycle is initiated.
6. **Speaker Outputs** – The SP+ and SP- pins provide direct drive for loudspeakers with impedances as low as 8Ω.
7. **MIC** – Microphone Input, the microphone input transfers its signals to the on-chip preamplifier.
8. **FT** – Feed Through: This mode enable the Microphone to drive the speaker directly.
9. **P-E** – Play the records endlessly.

Record Operate Guide

1. Push REC button then the RECLEd will light and keep push until record end.
2. Release the REC button
3. Select Playback mode: PLAYE, just need push one time, and will playback all of the record or power down ; PLAYL, you need always push this button until you want to stop playback record or end ; When short P-E jumper the record will playback time a time until jumper off or power down
4. FT mode, when short FT jumper, that means all of you speak to MIC will direct playback to Speaker.

4 Power Amplifier Circuit

If you want extern power amplifier circuit to Speakers, you can use LM386, D2283, D2322, TA7368, MC34119 etc amplifier IC. Note, SP+ or SP- is you do not want to use, must vacant, do not connect to GND. Used LM386 power amplifier circuit as below:

